

Positive Displacement Air Blowers

HR10, 11, 12, 13 Blower Range:
127 - 1299 (M³/HR)

Based on Success

HR Blowers are one of the world's leading air blower manufacturers and have a reputation for quality, innovation and service.

Design Features

The conservative load carrying capacity of the larger diameter rolling element bearings ensures an extended operating life.

Timing gear life is also extended by controlled lubrication systems.

The computer calculated impeller profiles ensure maximum volumetric efficiency with minimum absorbed power without sacrificing torsional rigidity.

The high rigidity of the impeller / shafts permits a higher pressure rise to be obtained than with other machines of comparable size.

The generous shaft diameter keeps drive stresses low.

Gear and shaft strength is substantially increased by the use of taper mounted gears which do not need keyways for location. Setting of the gear wheels to obtain correct timing of the impellers is simplified, a feature that facilitates field maintenance.

Precision ground and hardened steel gears are used to ensure smooth, silent running and accurate timing of the rotating impellers. A controlled lubrication system is provided to ensure efficient operation without waste of energy in the gearcase.

Specially designed rotary oil seals are used in the gearcase. This feature eliminates maintenance associated with the use of lip seals.

Design and manufacture is in accordance with metric standards.

Use as an Exhauster

If used as an exhauster and dust or liquids could be drawn into the machine due to inadequate filtration, closed end rotors should be specified. This will minimise risk of loss of dynamic balance due to material inside the rotors.

Specification

CASING: The cylinder and headplates are manufactured from cast iron. The gearcase is manufactured from aluminium.

IMPELLERS AND SHAFTS: The impellers are made from SG iron, and cast with integral shafts. The shaft diameter of machines in the HR Blowers range is larger than that of earlier designs, enabling increased operating pressures to be achieved without increasing blower size.

GEARS: The precision ground and hardened steel spur gears are taper mounted onto the impeller shafts. The timing of the impellers relative to each other is accurately maintained at all times.

BEARINGS: The bearings are of generous proportions to give long operational life. Grease lubricated double row ball bearings are used at the drive end of the blower. In addition to their normal duty of carrying radial loads associated with the differential air pressure on the rotating impellers, the ball bearings provide axial location of the impellers. Parallel roller bearings at the rear end splash lubrication by oil from the gears.

LUBRICATION: An advanced design of controlled gear wheel lubrication enables the gears to operate at a high pitch line velocity without the need for an oil pump. Simple, maintenance free oil throwers fitted behind each bearing in the gearcase prevent leakage of oil.

DIRECTION OF ROTATION: Detachable mounting feet enable the blower to be positioned for either vertical or horizontal air flow. Standard machines have a right hand drive shaft for vertical air flow, and a bottom drive shaft for horizontal air flow. If machines are required with a left hand or top drive shaft, all that needs to be done is turn the gearcase and trough through 180°. Centre timing permits clockwise or anti-clockwise drive shaft rotation.



User Benefits

- The delivered air is guaranteed to be oil free because internal lubrication is unnecessary, and because all HR Blowers Positive Displacement Air Blowers are constructed with air gaps which completely isolate bearing and gear lubrication from the compression chamber.
- Noise levels are kept to a minimum. Mechanical noise levels have been reduced by the running accuracy of the taper mounted gears. Air noise is reduced by carefully designed air ports and the elimination of resonant unbraced surfaces.
- The blower can be installed for either vertical or horizontal air flow simply by repositioning the mounting feet. Installation costs can be reduced by versatility of mounting arrangement.
- The generous diameter of the drive shaft permits the use of V-belt drives without the need for a double outer bearing.
- Air blowers can also be used as air exhausters. Performance charts on application.

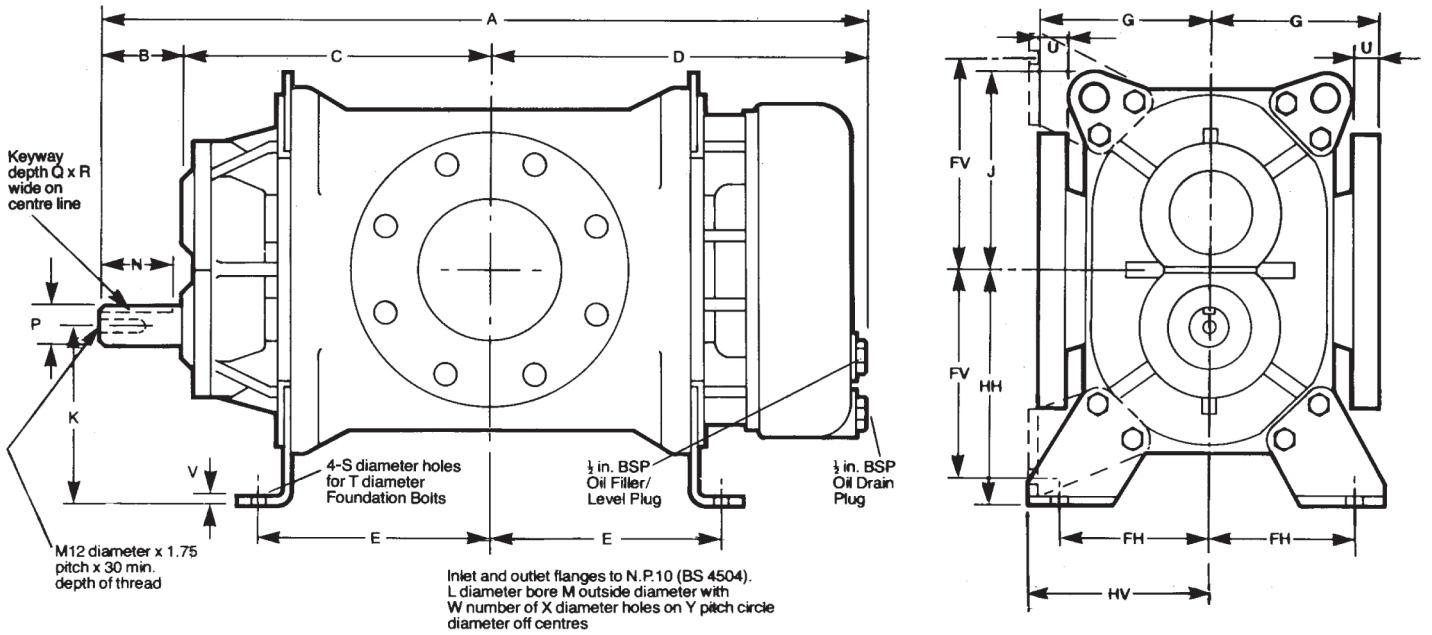

Dimensions

Size	Horizontal Flow					Vertical Flow										All dimensions in millimetres												
	A	B	C	D	E	F _H	H _H	E	F _V	H _V	G	J	K	L	M											N	P	Q
HR10	454	70	165	219	95	130	205	95	180	155	153	173	155	100	220	65	32.018/32.002	5.0/5.2	9.964/10.00	14	12	21	6	8	18	180		
HR11	504		190	244	120			120																				
HR12	597		235	292	165			165																			23	210
HR13	667		270	327	200			200																				

Blower Performance

HR Size	Speed rpm	300 mbar		500 mbar		700 mbar		1000 mbar	
		M ³ /HR	kW	M ³ /HR	kW	M ³ /HR	kW	M ³ /HR	kW
10	3485	514	6.0	490	9.3	472	12.7	449	17.8
	3000	429	5.1	406	8.0	388	10.9	365	15.3
	2500	342	4.3	319	6.7	301	9.1	278	12.7
	2000	256	3.4	232	5.4	214	7.3	—	—
	1500	169	2.6	146	4.0	127	5.5	—	—
11	3485	697	7.8	666	12.3	641	16.9	611	23.8
	3000	583	6.7	552	10.6	527	14.6	496	20.5
	2500	465	5.6	434	8.9	409	12.1	378	17.0
	2000	347	4.5	316	7.1	291	9.7	—	—
	1500	229	3.3	198	5.3	173	7.3	—	—
12	3485	1032	11.0	987	17.8	951	24.5	—	—
	3000	864	9.5	819	15.3	783	21.1	—	—
	2500	690	7.9	645	12.7	609	17.6	—	—
	2000	516	6.3	471	10.2	—	—	—	—
	1500	343	4.7	298	7.6	—	—	—	—
13	3485	1299	13.5	1244	22.0	Maximum pressure rise for size 13 is 550 mbar. See performance chart for details			
	3000	1088	11.7	1034	18.9				
	2500	871	9.7	817	15.8				
	2000	654	7.8	600	12.6				
	1500	437	5.8	383	9.5				

The volume of air delivered is measured at inlet conditions of 15°C and 1013 mbar absolute

Weight

Net Weight	Size 10: 76kg Size 11: 82kg Size 12: 102kg Size 13: 106kg
-------------------	--

For accurate performance characteristics please contact HR Blowers