

# Positive Displacement Air Blowers

**HR61, 62, 63** Blower Range:  
4265-22150 (M<sup>3</sup>/HR)

## Based on Success

HR Blowers are one of the world's leading air blower manufacturers and have a reputation for quality, innovation and service.

### Design Features

The conservative load carrying capacity of the larger diameter rolling element bearings ensures an extended operating life.

Timing gear life is also extended by controlled lubrication systems.

The computer calculated impeller profiles ensure maximum volumetric efficiency with minimum absorbed power without sacrificing torsional rigidity.

The high rigidity of the impeller / shafts permits a higher pressure rise to be obtained than with other machines of comparable size. The generous shaft diameter keeps drive stresses low.

Gear and shaft strength is substantially increased by the use of taper mounted gears which do not need keyways for location. Setting of the gear wheels to obtain correct timing of the impellers is simplified, a feature that facilitates field maintenance.

Precision ground and hardened steel gears are used to ensure smooth, silent running and accurate timing of the rotating impellers. A controlled lubrication system is provided to ensure efficient operation without waste of energy in the gearcase.

Specially designed rotary oil seals are used in the gearcase. This feature eliminates maintenance associated with the use of lip seals.

Design and manufacture is in accordance with metric standards.

### Use as an Exhauster

If used as an exhauster and dust or liquids could be drawn into the machine due to inadequate filtration, closed end rotors should be specified. This will minimise risk of loss of dynamic balance due to material inside the rotors.

### Specification

**CASING:** The cylinder, headplates and gearcase are manufactured from cast iron. The cylinder on sizes 62, 63, 72 and 73 machines incorporates inspection covers which facilitate the checking of internal clearances.

**IMPELLERS AND SHAFTS:** The impellers are made from ductile and have pressed steel shafts. The shaft diameter of machines in the HR range is larger than that of earlier designs enabling increased operating pressure to be achieved without increasing blower size.

**GEARS:** The precision ground and hardened steel spur gears are taper mounted onto the impeller shafts. The timing of the impellers relative to each other is accurately maintained at all times.

**BEARINGS:** The bearings are of generous proportions to give long operational life. Grease lubricated parallel roller bearings are used at the drive end of the blower. Spherical roller bearings at the opposite end are splash lubricated from the gears. In addition to their normal duty of carrying radial loads associated with the differential air pressure on the rotating impellers, the spherical bearings provide axial location of the impellers.

**LUBRICATION:** An advanced design of controlled gear wheel lubrication enables the gears to operate at a high pitch line velocity without the need for an oil pump. Simple, maintenance free oil throwers fitted behind each bearing in the gearcase prevent leakage of oil.

**DIRECTION OF ROTATION:** Standard machines have top air inlet and bottom discharge with a right hand shaft rotating in a clockwise direction. Bottom inlet and top discharge and/or left hand shaft can be supplied if specified at time of order.

**BLOWER PROTECTION SYSTEM:** (optional extra). A number of insulated probes projecting into the cylinder which are electrically connected to one another and to a junction box mounted on the blower can be fitted. To operate this system a control box is also required. The protection system (UK and foreign patents granted) detects excessive closure of the fine working clearances within the blower which might be caused by overload. Should this happen, the prime mover is shut down automatically to prevent seizure of the blower.



### User Benefits

- The delivered air is guaranteed to be oil free because internal lubrication is unnecessary, and because all HR Blowers Positive Displacement Air Blowers are constructed with air gaps which completely isolate bearing and gear lubrication from the compression chamber.
- Noise levels are kept to a minimum. Mechanical noise levels have been reduced by the running accuracy of the taper mounted gears. Air noise is reduced by carefully designed air ports and the elimination of resonant unbraced surfaces.
- The generous diameter of the drive shaft permits the use of V-belt drives without the need for a double outer bearing.
- A patented blower protection device can be supplied. This is designed to trip the drive motor and shut down the blower if the internal clearances are reduced to a dangerous level.
- Thermostatically controlled heaters can be fitted as an optional extra. These regulate lubricating oil temperatures, and permit the use of a single grade oil under widely varying ambient conditions.
- Air blowers can also be used as air exhausters. Performance charts on application.

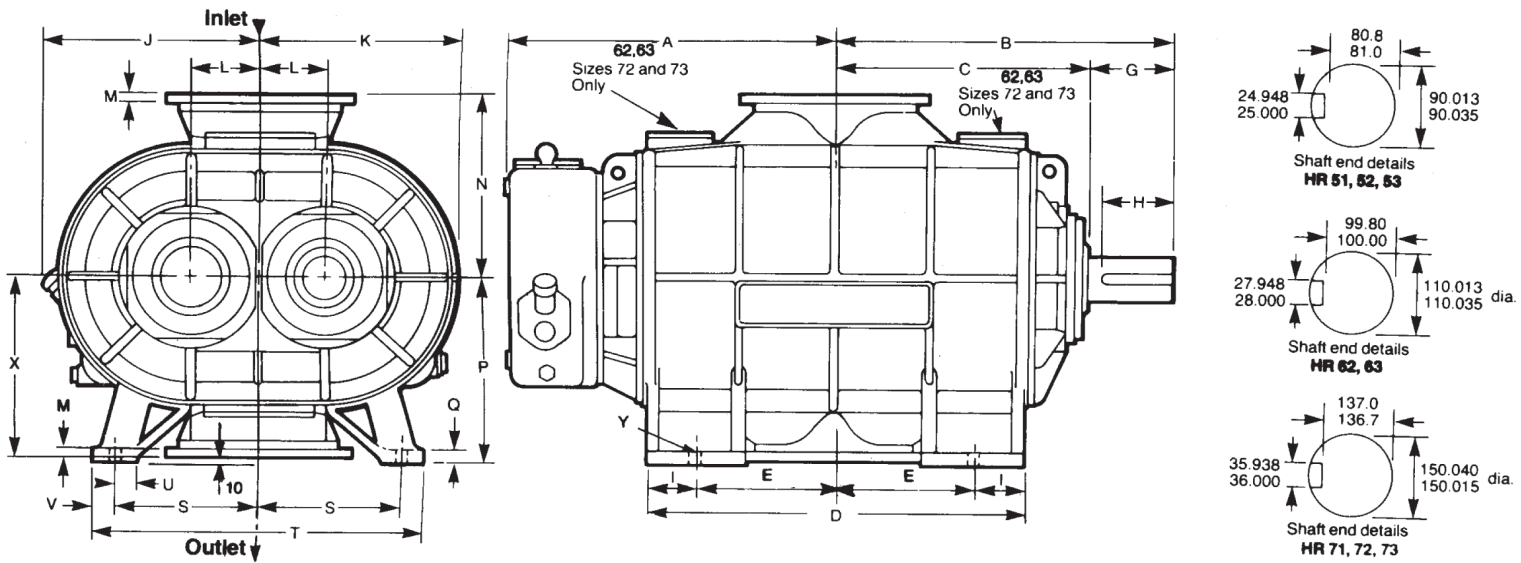

**Inlet and Outlet Flanges / Net Weight**

Size 61: 350 dia. bore 490 o/dia. with 12 holes 22 dia. equally spaced on 445 pcd. off centres  
 Size 62: 400 dia. bore 540 o/dia. with 16 holes 22 dia. equally spaced on 495 pcd. off centres  
 Size 63: 500 dia. bore 645 o/dia. with 20 holes 22 dia. equally spaced on 600 pcd. off centres

**Dimensions**

Size	A	B	C	D	E	G	H	I	J	K	L	M	N	P	Q	S	T	U	V	X	Y	
HR61	760	745	520	690	430																	4-27mm dia holes for 24mm dia holding down bolts
HR62	910	895	670	990	365	225	180	130	600	540	180	25	490	500	35	390	880	70	50	490		
HR63	1035	1020	795	1240	490																	

**Blower Performance**

HR Size	Speed rpm	300 mbar		500 mbar		700 mbar		1000 mbar	
		M <sup>3</sup> /HR	kW	M <sup>3</sup> /HR	kW	M <sup>3</sup> /HR	kW	M <sup>3</sup> /HR	kW
61	1215	12335	123	11953	200	11650	277	11276	392
	1000	9884	101	9502	165	9200	228	8825	323
	800	7604	81	7222	132	6920	182	6545	258
	600	5324	61	4942	99	4639	137	4265	194
62	1215	17650	172	17126	282	16710	392	—	—
	1000	14159	141	13635	232	13219	322	—	—
	800	10911	113	10387	185	9971	258	—	—
	600	7663	85	7139	139	6723	193	—	—
63	1215	22150	213	21500	350	Maximum pressure rise for size 63 is 550 mbar See performance chart for details.			
	1000	17795	175	17174	288				
	800	13743	140	13122	230				
	600	9692	105	9071	173				

**Weight**

<b>Net Weight</b>	Size 61: 2190kg Size 62: 2312kg Size 63: 2502kg
-------------------	-------------------------------------------------------

The volume of air delivered is measured at inlet conditions of 15°C and 1013 mbar absolute

For accurate performance characteristics please contact HR Blowers