

# Tri-lobe Blowers Trinado/Scirocco

**210, 208** Blower Range:  
**1047-5451 (M<sup>3</sup>/HR)**

## Based on Success

HR Blowers are one of the world's leading air blower manufacturers and have a reputation for quality, innovation and service.

### Design Features

The Scirocco Blower has been specially designed to reduce noise and power loss by utilising an exclusive wrap-around plenum and proprietary double Whispair® jet to control pressure equalisation - (feeding backflow in the direction of impeller movement, thereby aiding rotation).

The computer calculated impeller profiles ensures maximum volumetric efficiency with minimum absorbed power without sacrificing torsional rigidity.

The conservative load carrying capacity of the larger diameter rolling element bearings ensures an extended operating life. Timing gear life is also extended by a controlled lubrication system.

The gear and shaft strengths are substantially increased by the use of taper mounted gears which do not need keyways for location. Setting of the gear wheels to obtain correct timing of the impellers is simplified, a feature that facilitates field maintenance.

### Specification

**CASING:** The cylinder and headplates are manufactured from cast iron.

**IMPELLERS AND SHAFTS:** The dynamically balanced impellers have integral shafts and are made from ductile shafts.

The high rigidity of the impeller/shafts permits a higher pressure rise to be obtained than with other machines of comparable size. The generous shaft diameter keeps drive stresses low.

**GEARS:** Precision Ground Gears are used to ensure smooth, silent running and accurate timing of the rotary impellers. A controlled lubrication system is provided to ensure efficient operation without waste of energy in the gearcase. Timing gears are hardened and precision ground, spur gears are manufactured from high grade alloy steel.

**BEARINGS:** The bearings at the drive end of the blower are spherical roller type of generous proportions to give long operational life. Parallel roller bearings are fitted at the gear end and are splash lubricated by oil from the gears.

**LUBRICATION:** Specially designed labyrinth seals and oil throwers are used at both ends. This feature eliminates maintenance associated with the use of lip seals. The Scirocco Whispair® blowers are constructed with air gaps which isolate the bearing and gear lubricants from the compression chamber.

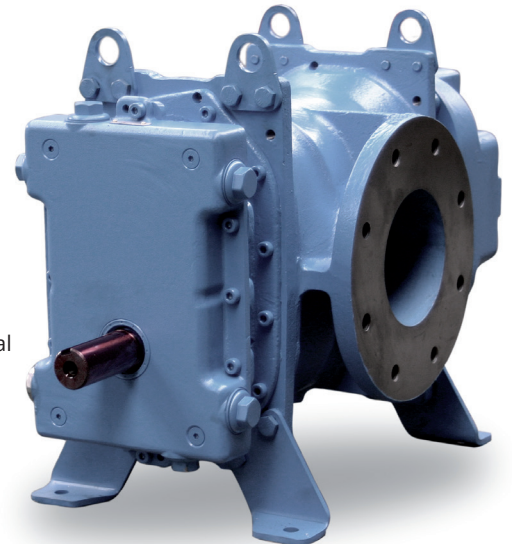

### User Benefits

- The delivered air is guaranteed to be oil free because internal lubrication is unnecessary, and because the Scirocco Range of Positive Displacement Air Blowers are constructed with air gaps which completely isolate bearing and gear lubricants from the compression chamber.
- Noise Levels are kept to a minimum. Air noise is reduced by carefully designed air ports (utilising the special Whispair feature and by the elimination of resonant unbraced surfaces. Mechanical noise levels have been reduced by running accuracy of the taper mounted gears.
- The blower can be installed for either vertical or horizontal air flow simply by repositioning the mounted feet. Installation costs can be reduced by the versatility of mounting arrangements.
- The generous diameter of the drive shaft permits the use of V-belt drives without the need for a double outer bearing.
- Centre timing permits clockwise or anti-clockwise drive shaft rotation.

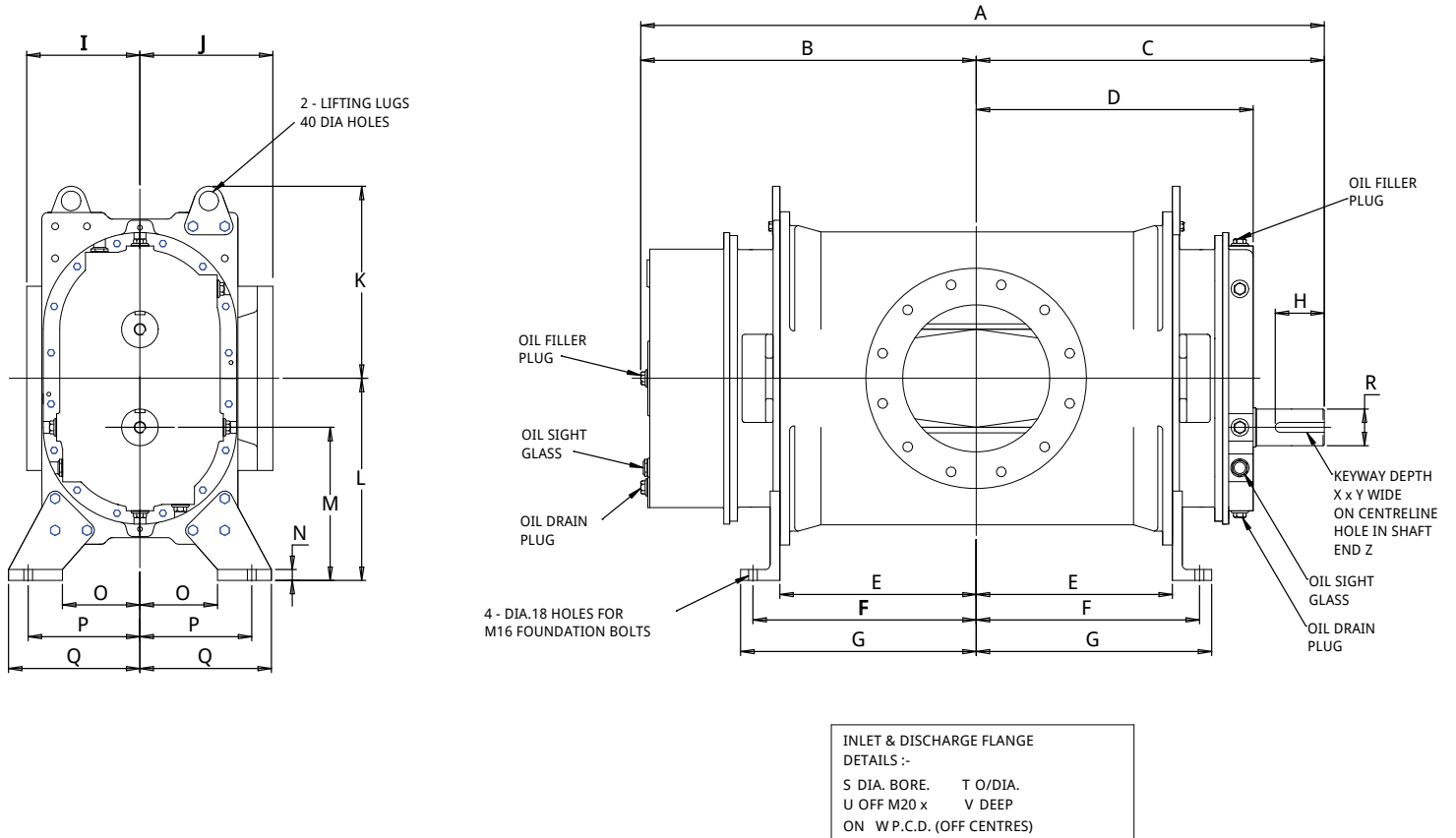

### Dimensions

Size	A	B	C	D	E	F	G	H	I	J	K	L	M	N	O	P	Q	R	S	T	U	V	W	X	Y	Z
208	1200	627	573	455	320	372.5	395	100	185	217	337	330	250	20	114	179.5	219.5	60.011/60.030	250	395	12 off M20	24	350	7	18	M24
210	1040	547	493	375	240	292.5	315	100	185	217	337	330	250	20	114	179.5	219.5	60.011/60.030	200	340	8 off M20	24	295	7	18	M24

### Blower Performance

	SPEED	300mbar		500mbar		700mbar		1000mbar	
		M <sup>3</sup> /HR	kW	M <sup>3</sup> /HR	kW	M <sup>3</sup> /HR	kW	M <sup>3</sup> /HR	kW
210	1200	1247	18.5	1137	30	1047	37	—	—
	1500	1653	22	1543	37	1454	45	1341	75
	2000	2330	30	2220	45	2131	75	2018	90
	2500	3008	37	2897	55	2808	75	2695	110
	3000	3685	45	3575	75	3485	90	3372	132
	3300	4091	55	3981	75	3891	110	3779	150
208	1200	1662	22	1515	37	1396	55	—	—
	1500	2203	30	2125	45	1937	75	—	—
	2000	3105	37	302	55	2839	75	—	—
	2500	4008	55	3930	75	3742	110	—	—
	3000	4910	55	4832	90	4644	132	—	—
	3300	5451	75	4032	110	5185	132	—	—

For accurate performance characteristics please contact HR Blowers