

Positive Displacement Air Blowers

HR31,32,33 Blower Range:
792-4367 (M³/HR)

Based on Success

HR Blowers are one of the world's leading air blower manufacturers and have a reputation for quality, innovation and service.

Design Features

The conservative load carrying capacity of the larger diameter rolling element bearings ensures an extended operating life.

Timing gear life is also extended by controlled lubrication systems.

The computer calculated impeller profiles ensure maximum volumetric efficiency with minimum absorbed power without sacrificing torsional rigidity.

The high rigidity of the impeller / shafts permits a higher pressure rise to be obtained than with other machines of comparable size. The generous shaft diameter keeps drive stresses low.

Gear and shaft strength is substantially increased by the use of taper mounted gears which do not need keyways for location. Setting of the gear wheels to obtain correct timing of the impellers is simplified, a feature that facilitates field maintenance.

Precision ground and hardened steel gears are used to ensure smooth, silent running and accurate timing of the rotating impellers. A controlled lubrication system is provided to ensure efficient operation without waste of energy in the gearcase.

Specially designed rotary oil seals are used in the gearcase. This feature eliminates maintenance associated with the use of lip seals. Design and manufacture is in accordance with metric standards.

Use as an Exhauster

If used as an exhauster and dust or liquids could be drawn into the machine due to inadequate filtration, closed end rotors should be specified. This will minimise risk of loss of dynamic balance due to material inside the rotors.

Specification

CASING: The cylinder and headplates are manufactured from cast iron. The gearcase is manufactured from aluminium.

IMPELLERS AND SHAFTS: The impellers are made from SG iron, and cast with integral shafts. (size 3) and from mehanite and have pressed-in steel shafts (size 4). The shaft diameter of machines in the HR Blowers range is larger than that of earlier designs,

enabling increased operating pressures to be achieved without increasing blower size.

GEARS: The precision ground and hardened steel spur gears are taper mounted onto the impeller shafts. The timing of the impellers relative to each other is accurately maintained at all times.

BEARINGS: The bearings are of generous proportions to give long operational life. Grease lubricated double row ball bearings are used at the drive end of the size 3 Blower the size 4 blower has double angular roller bearings at the drive end. In addition to their normal duty of carrying radial loads associated with the differential air pressure on the rotating impellers, the ball bearings provide axial location of the impellers. Parallel roller bearings at the rear end splash lubrication by oil from the gears.

LUBRICATION: An advanced design of controlled gear wheel lubrication enables the gears to operate at a high pitch line velocity without the need for an oil pump. Simple, maintenance free oil throwers fitted behind each bearing in the gearcase prevent leakage of oil.

DIRECTION OF ROTATION: Detachable mounting feet enable the blower to be positioned for either vertical or horizontal air flow. Standard machines have a right hand drive shaft for vertical air flow, and a bottom drive shaft for horizontal air flow. If machines are required with a left hand or top drive shaft, all that needs to be done is turn the gearcase and trough through 180°. Centre timing permits clockwise or anti-clockwise drive shaft rotation.

BLOWER PROTECTION SYSTEM: (optional extra). A number of insulated probes projecting into the cylinder which are electrically connected to one another and to a junction box mounted on the blower can be fitted. To operate this system a control box is also required. The protection system (UK and foreign patents granted) detects excessive closure of the fine working clearances within the blower which might be caused by overload. Should this happen, the prime mover is shut down automatically to prevent seizure of the blower.

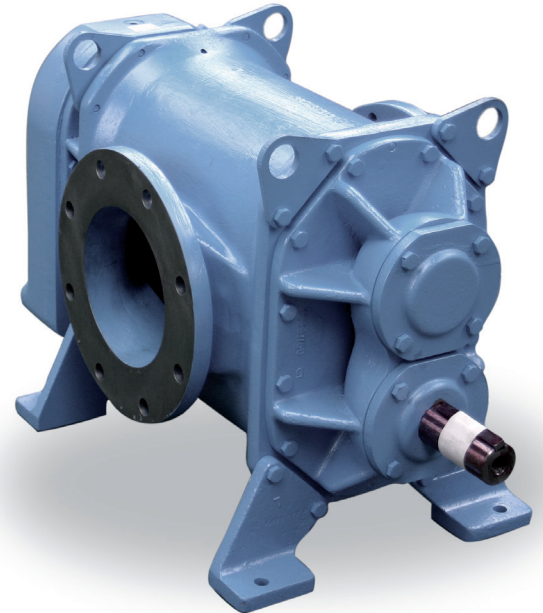

User Benefits

- The delivered air is guaranteed to be oil free because internal lubrication is unnecessary, and because all HR Blowers Positive Displacement Air Blowers are constructed with air gaps which completely isolate bearing and gear lubrication from the compression chamber.
- Noise levels are kept to a minimum. Mechanical noise levels have been reduced by the running accuracy of the taper mounted gears. Air noise is reduced by carefully designed air ports and the elimination of resonant unbraced surfaces.
- The blower can be installed for either vertical or horizontal air flow simply by repositioning the mounting feet. Installation costs can be reduced by versatility of mounting arrangement.
- The generous diameter of the drive shaft permits the use of V-belt drives without the need for a double outer bearing.
- Air blowers can also be used as air exhausters. Performance charts on application.

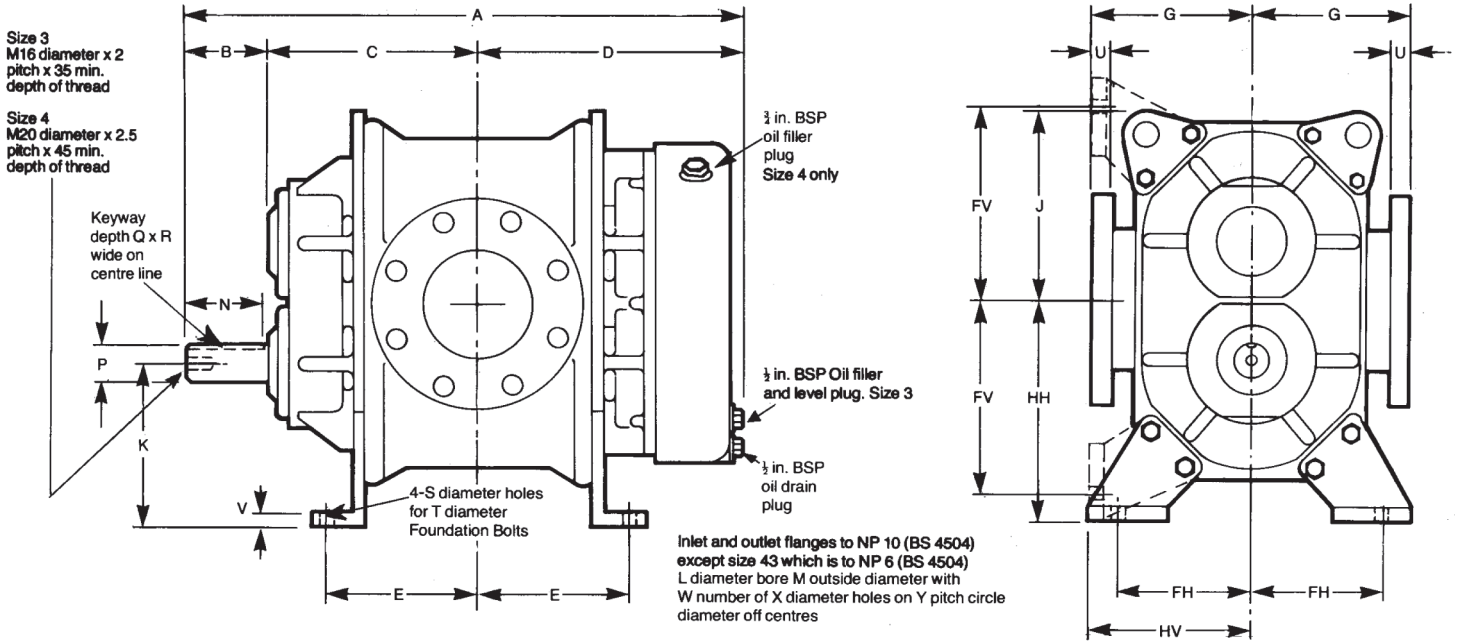

Dimensions

Size	Horizontal Flow					Vertical Flow					All dimensions in millimetres																
	A	B	C	D	E	F _H	H _H	E	F _V	H _V	G	J	K	L	M	N	P	Q	R	S	T	U	V	W	X	Y	
HR31	751		283	353	205			205						150	285												240
HR32	891	115	353	423	275	180	300	275	260	220	215	254	220	200	340	110	50.018/50.002	5.5/5.7	14.05/14.12	18	16	25	20	8	22	295	
HR33	1005		410	480	333			333						200	340											295	

Blower Performance

HR Size	Speed rpm	300 mbar		500 mbar		700 mbar		1000 mbar	
		M ³ /HR	kW	M ³ /HR	kW	M ³ /HR	kW	M ³ /HR	kW
31	2720	2360	24.4	2291	39.1	2236	53.8	2168	75.8
	2500	2147	22.5	2078	35.9	2023	49.4	1955	69.6
	2300	1953	20.7	1884	33.1	1829	45.5	1761	64.1
	2100	1759	18.9	1690	30.2	1635	41.5	1567	58.5
	1900	1566	17.0	1496	27.3	1441	37.6	1374	52.9
	1700	1372	15.3	1303	24.4	1248	33.6	1180	47.3
	1500	1178	13.5	1109	21.6	1054	29.6	986	41.8
	1300	984	11.7	915	18.7	860	25.7	792	36.2
32	2720	3455	34.5	3356	55.9	3279	77.3	—	—
	2500	3144	31.7	3045	51.4	2968	71.1	—	—
	2300	2861	29.2	2763	47.3	2685	65.4	—	—
	2100	2578	26.7	2480	43.2	2402	59.7	—	—
	1900	2296	24.1	2197	39.1	2120	54.0	—	—
	1700	2013	21.6	1915	35.0	1837	48.3	—	—
	1500	1730	19.0	1632	30.8	1554	42.6	—	—
1300	1448	16.5	1350	26.7	1272	37.0	—	—	
33	2720	4367	42.8	4249	69.7	Maximum pressure rise for size 33 is 550 mbar See performance chart for details.			
	2500	3976	39.4	3558	64.1				
	2300	3621	36.2	3502	59.0				
	2100	3265	33.1	3146	53.8				
	1900	2909	29.9	2791	48.7				
	1700	2553	26.8	2435	43.6				
	1500	2198	23.6	2079	38.5				
	1300	1842	20.5	1724	33.3				

The volume of air delivered is measured at inlet conditions of 15°C and 1013 mbar absolute

Weight

Net Weight	Size 31: 236kg Size 32: 282kg Size 33: 306kg
------------	--

For accurate performance characteristics please contact HR Blowers